

**High Productivity Cooking
 thermaline 80 - Freestanding Electric
 Multi Braiser, 2/1GN, 1 Side, Backsplash,
 H=700**

ITEM # _____

MODEL # _____

NAME # _____

SIS # _____

AIA # _____



588190 (MAADEBHDAO) Electric Multi Braiser, one-side operated with backsplash, 2/1 GN

Short Form Specification

Item No. _____

Unit constructed according to DIN 18860_2 with 20 mm drop nose top and 70 mm recessed plinth. Internal frame for heavy duty sturdiness in stainless steel. 2 mm top in 1.4301 (AISI 304). Flat surface construction, easily cleanable. THERMODUL connection system enables seamless worktop when units are connected and avoids soil penetrating. Multi-purpose cooking appliance which can be used to shallow fry, cook liquids or as a bain marie. 18 mm-thick stainless steel plated bottom, seamlessly welded to the chrome nickel steel well. Powerblock heating system for optimal temperature distribution, which can be set up to 280°C. Interior pan dimensions allows the use of GN containers. Large drain hole allows to drain the cooking juices into a large collector. All-round basin raised edges to protect against soil infiltration. Overheat protection switches off the supply in case of overheating. Standby function saves energy and quickly recovers maximum power. Metal knobs with embedded hygienic silicon "soft" grip enable easier handling and cleaning. IPX5 water resistant certification. Configuration: Freestanding, one-side operated with backsplash.

Main Features

- Choice of one or two heating zones. An indicator lamp shows operating state of each zone.
- Large drain hole on cooking surface permits the draining of residual cooking juices into a large collector placed under the cooking surface.
- Multi purpose cooking appliance that can be used to shallow fry, cook liquids or even as a bain marie. Unit can be used for sautéing, poaching, steaming, simmering, stewing, braising, boiling and preparing white sauces.
- Overheat protection: the temperature sensor switches off the supply in case of overheating.
- All major components may be easily accessed from the front.
- THERMODUL connection system creates a seamless work top when units are connected to each other thus avoiding soil penetrating vital components and facilitating the removal of units in case of replacement or service.
- Metal knobs with embedded hygienic "soft-touch" grip for easier handling and cleaning. The special design of the controls prevents infiltration of liquids or soil into vital components.
- Powerblock heating system for optimal temperature distribution.
- Raised edge all around the well to protect from infiltration of dirt from worktop.
- Temperature can be set up to a maximum of 280 °C.
- Interior dimensions of the well enables the use of GN containers.
- Large visible digital display manufactured in tempered glass to resist heat and chemicals, showing temperatures or power settings. The display also shows on/off status of the appliance and on/off status of the heating elements.
- Handles are ergonomically designed with silicon "soft" grip for easy handling and cleaning.

Construction

- An 18 mm thick stainless steel plated bottom is seamlessly welded into the chrome nickel steel well.
- Rounded corners and edges aid cleaning.
- Storage space in the base of the appliance that can accept GN1/1 containers.
- 2 mm top in 1.4301 (AISI 304).
- IPX5 water resistance certification.
- Flat surface construction with minimal hidden areas to easily clean all surfaces

APPROVAL: _____

- Unit constructed according to DIN 18860_2 with 20 mm drop nose top and 70 mm recessed plinth.
- Internal frame for heavy duty sturdiness in stainless steel.

Sustainability



- Standby function for energy saving and fast recovery of maximum power.

Optional Accessories

- Lid for multi braisers, 2/1 GN PNC 910621
- Connecting rail kit for appliances with backsplash, 800mm PNC 912497
- Portioning shelf, 800mm width PNC 912526
- Portioning shelf, 800mm width PNC 912556
- Folding shelf, 300x800mm PNC 912577
- Folding shelf, 400x800mm PNC 912578
- Fixed side shelf, 200x800mm PNC 912583
- Fixed side shelf, 300x800mm PNC 912584
- Fixed side shelf, 400x800mm PNC 912585
- Stainless steel front kicking strip, 800mm width PNC 912634
- Stainless steel side kicking strip left and right, against the wall, 800mm width PNC 912658
- Stainless steel side kicking strip left and right, back-to-back, 1610mm width PNC 912661
- Stainless steel plinth, against wall, 800mm width PNC 912844
- Connecting rail kit for appliances with backsplash: modular 80 (on the left), ProThermetic tilting (on the right), ProThermetic stationary (on the left) to ProThermetic tilting (on the right) PNC 912977
- Connecting rail kit for appliances with backsplash: modular 80 (on the right), ProThermetic tilting (on the left), ProThermetic stationary (on the right) to ProThermetic tilting (on the left) PNC 912978
- Back panel, 800x700mm, for units with backsplash PNC 913013
- Stainless steel panel, 800x700mm, against wall, left side PNC 913093
- Stainless steel panel, 800x700mm, against the wall, right side PNC 913097
- Endrail kit, flush-fitting, with backsplash, left PNC 913113
- Endrail kit, flush-fitting, with backsplash, right PNC 913114
- Scraper for smooth plates PNC 913119
- Blades with rounded sides for scraper PNC 913123
- Endrail kit (12.5mm) for thermaline 80 units with backsplash, left PNC 913204
- Endrail kit (12.5mm) for thermaline 80 units with backsplash, right PNC 913205
- U-clamping rail for back-to-back installations with backsplash (to be ordered as S-code) PNC 913226
- Insert profile D=800mm PNC 913230

- Perforated shelf for warming cabinets and cupboard bases (one-side operated TL80-85-90 and two-side operated for TL80) PNC 913234
- Energy optimizer kit 18A - factory fitted PNC 913245
- Side reinforced panel only in combination with side shelf, for against the wall installations, left PNC 913263
- Side reinforced panel only in combination with side shelf, for against the wall installations, right PNC 913265
- Shelf fixation for TL80-85-90 one-side operated, TL80 two-side operated PNC 913281
- Filter W=800mm PNC 913665
- Stainless steel dividing panel, 800x700mm, (it should only be used between Electrolux Professional thermaline Modular 80 and thermaline C80) PNC 913668
- Stainless steel side panel, 800x700mm, flush-fitting (it should only be used against the wall, against a niche and in between Electrolux Professional thermaline and ProThermetic appliances and external appliances - provided that these have at least the same dimensions) PNC 913684

Recommended Detergents

- C41 HI-TEMP RAPID DEGREASER, 1 pack of six 1 lt. bottles (trigger incl.) PNC 0S2292

Front

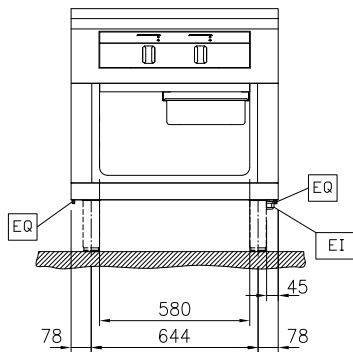

Side

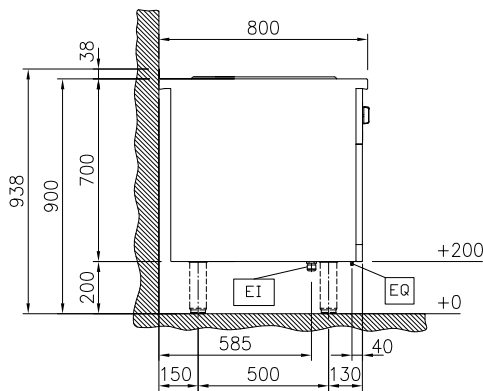

EI = Electrical inlet (power)

Top

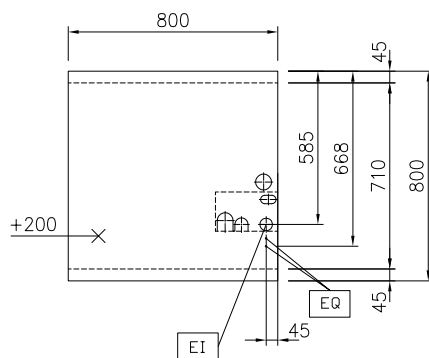

Electric

Supply voltage:	400 V/3N ph/50/60 Hz
Total Watts:	10.2 kW

Key Information:

Usable well dimensions (width):	630 mm
Usable well dimensions (height):	110 mm
Usable well dimensions (depth):	510 mm
Cooking Well Height:	110 mm
Well Capacity, Max:	22 lt
Working Temperature MIN:	80 °C
Working Temperature MAX:	280 °C
External dimensions, Width:	800 mm
External dimensions, Depth:	800 mm
External dimensions, Height:	700 mm
Storage Cavity Dimensions (width):	580 mm
Storage Cavity Dimensions (height):	330 mm
Storage Cavity Dimensions (depth):	740 mm
Net weight:	140 kg
Configuration:	Rectangular;Fixed;With splashback

Sustainability

Current consumption:	14.7 Amps
----------------------	-----------